

The Cryogenic Hydrogen Compressor system



A dynamic process that meets your high pressure and flow requirements

Industrial producers requiring high-pressure hydrogen for their process or application can now reduce costs and improve onstream time by using Air Products' Cryogenic Hydrogen Compressor (CHC) system. The proprietary technology is a liquid hydrogen supply system that provides complete operating flexibility for hydrogen flow rates up to 140,000 per hour scfh and for pressures up to 14,000 psig. Changing production needs can be matched instantly, reducing costs and minimizing downtime.



Multiple ways the CHC optimizes your process

Lower capital expense

Air Products' CHC system typically costs less to install than alternative supply options, such as on-site hydrogen generation or low-pressure liquid hydrogen supply when combined with gas compression. The efficiency of the CHC pumping system requires less capital investment to achieve the desired flow and pressure requirements.

Reduced operating costs through minimized vent losses

The CHC system can help minimize vent losses from the supply system. While many high-pressure hydrogen technologies use a liquid-only pump system, Air Products has designed a two-phase flow process that can capture gas formed through normal heat leak vaporization and deploy that gas into the process, resulting in operating savings.

Increased efficiency through load-following

The CHC's unique control technology is called load-following. In other words, its output can fluctuate and closely match changing demand requirements. While running continuously, the system supplies the flow rate needed by your process at any given time. This capability helps to minimize vent losses in the system, making Air Products' CHC technology more efficient than traditional liquid hydrogen pumps.

Air Products supports various industries including:

- Chemicals manufacturing
- Refineries
- Steel
- Metals processing
- Power generation
- Flavors and fragrances
- Resins and chemical intermediates
- Bio & synthetic fuel manufacturing
- Used oil recycling

And more! If your high pressure high flow industry is not shown, contact us at info@airproducts.com for your customized solution.

Hydrogen safety

At Air Products, safety is our first priority. That's why our CHC system comes with a complete hazard review. Air Products has installed hundreds of safe working systems across North America over the years. Our installation specialists can assist you in working with local officials to meet all defined safety requirements..

Easy to install

The CHC system consists of completely skidded modular components that can be installed easily and safely on your site. Equipment includes low-pressure product storage, the proprietary CHC pumping system, high-pressure vaporizers, high-pressure gas storage cylinders, and Air Products' load-following control systems.

Reliable supply

Reliable material supply is essential to excel in today's marketplace. Air Products recognizes this need. As the world's largest commercial liquid hydrogen producer, we have a network of distribution facilities located strategically throughout North America. Dedicated drivers and proprietary logistics software help us deliver our bulk gas products with a 99.95 percent on-time delivery record.

About Air Products

Air Products serves customers in virtually every industry, from operations in more than 40 countries around the globe. Founded in 1940, we are recognized for our innovative culture, operational excellence, and commitment to safety and the environment.

How the system works

Simplified P&ID, Cryogenic Hydrogen Compressor System

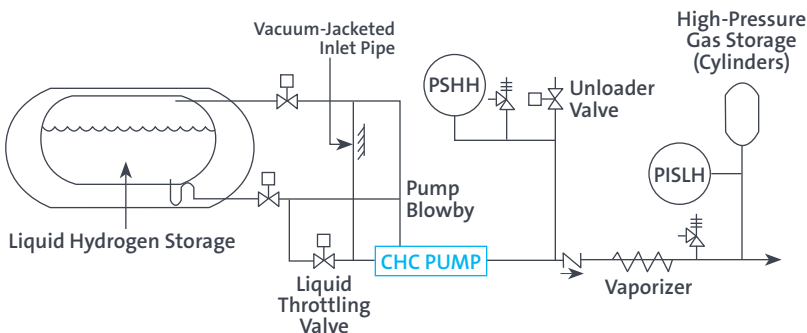

Liquid hydrogen is directed from the storage tank through vacuum-insulated piping to the suction of the CHC compressor. Inlet conditions are adjusted with a pneumatically operated control valve on the liquid line. The CHC unit compresses the liquid hydrogen to the required pressure through two compression ends in parallel. Cryogenic discharge flow is routed to the vaporizers to be warmed to ambient temperature. Recycle gas is routed back to either the pump suction or storage tank.

**For more information,
please contact us at:**

Corporate Headquarters

Air Products and Chemicals, Inc.
1940 Air Products Blvd.
Allentown, PA 18106-5500
T 610-481-4911
(Outside the U.S. and Canada
+1-610-481-6799)
info@airproducts.com
or visit airproducts.com



GENERATING A CLEANER FUTURE